

- Technical Remarks:
1. part smooth, uniform color, marking a clear, No cracking, delamination, lack of material, pattern, plug holes and other phenomena.
 2. Tolerance by SJ/T10628 if do not noted.

UNLESS OTHERWISE SPECIFIED ALL DIMENSIONS ARE IN MM TOLERANCES: WHOLE NO. ± 0.2 DECIMAL ± 0.1 ANGLE $\pm 0.5^\circ$							
MARK	REV	NAME	DATE	SIZE	REV	SCALE	PAGE
DESIGNER	XUWUYU		2009.05.08	A4		2:1	1/1
CHECKED	MEIJIAOLONG		2009.05.08				
APPROVAL	JIYAOHU		2009.05.08				
 浙江紫瑞电子有限公司 ZHEJIANG ZIRUI ELECTRONIC CO., LTD				MATERIAL: PA66 MODEL: 3191-2P FILE NO.: ZR7.810.102			

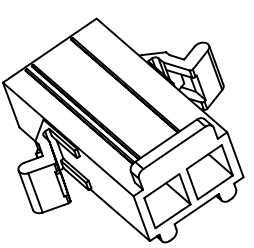
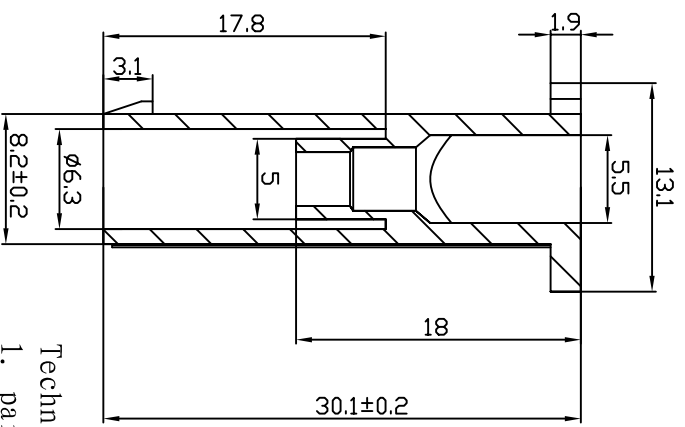
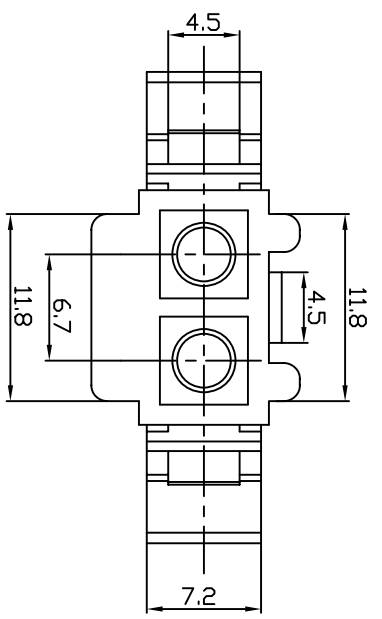
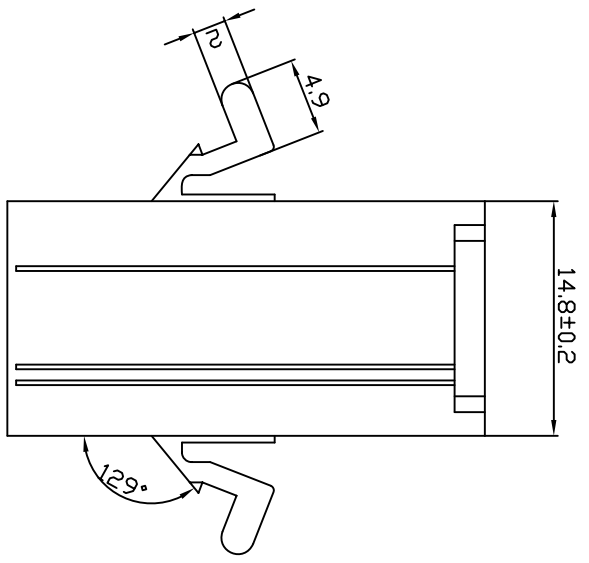
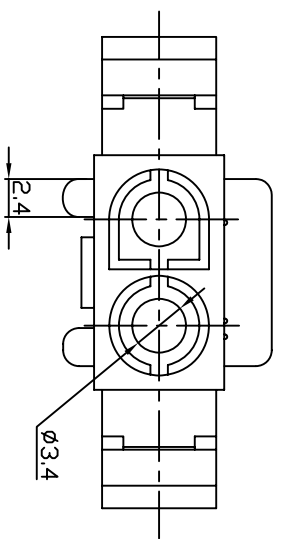

Technical Remarks:
 1. part smooth, uniform color, marking a clear,
 No cracking, delamination, lack of material,
 pattern, plug holes and other phenomena.
 2. Tolerance by SJ/T10628 if do not noted.

MARK		REV		NAME		DATE		UNLESS OTHERWISE SPECIFIED ALL DIMENSIONS ARE IN MM	
DESIGNER		XINGCUIHU		2011.07.10		2011.07.10		TOLERANCES: WHOLE NO. DECIMAL ANGLE	
CHECKED		MEIJIALONG		2011.07.10		A4		±0.2 ±0.1 ±0.5°	
APPROVAL		JIYAOHU		2011.07.10				SCALE PAGE	
								2:1 1/1	
								MATERIAL : PA66	
								MODEL: 3191-2R	
								FILE NO.: ZR7.810.098	



浙江紫瑞电子有限公司
 ZHEJIANG ZHIRUI ELECTRONIC CO., LTD

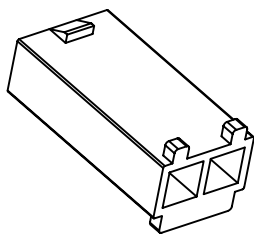
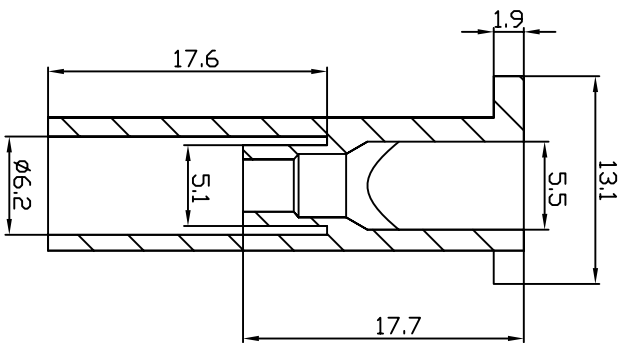
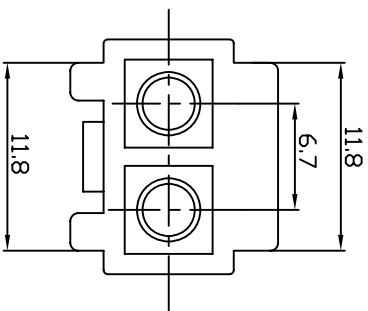
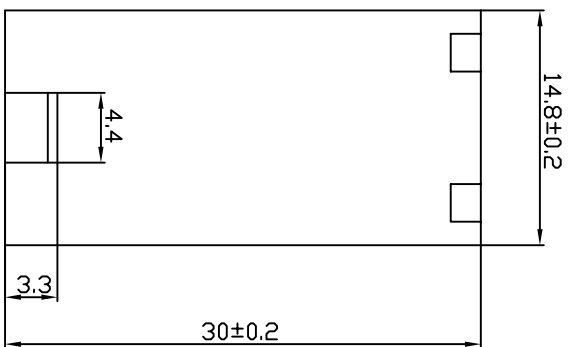
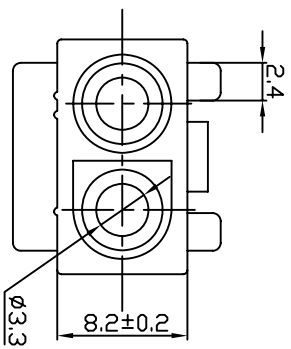

Technical Remarks:
 1. part smooth, uniform color, marking a clear,
 No cracking, delamination, lack of material,
 pattern, plug holes and other phenomena.
 2. Tolerance by SJ/T10628 if do not noted.

						UNLESS OTHERWISE SPECIFIED ALL DIMENSIONS ARE IN MM			
MARK	REV	NAME	DATE	SIZE	REV	SCALE	ANGLE		
				±0.2		±0.1	±0.5°		
DESIGNER	XINGCUIHU		2011.07.10	A4		2:1	1/1		
CHECKED	MEIJIALONG		2011.07.10						
APPROVAL	JIYAOHU		2011.07.10						
				MATERIAL : PA66		MODEL: 3191-2RF		FILE NO.: ZR7.810.095	
				 浙江紫瑞电子有限公司 ZHEJIANG ZHIRUI ELECTRONIC CO., LTD					